

kingland

kingland

kingland

kingland



Tailored Engineered Product Solutions

We use our computerized design selection program to focus on the fundamental engineering elements that provide suitable idlers for each application. We utilise world-class practices to deliver cost effective Hi Speed quality balanced rollers and idlers

that are suitable for today's heavy mining practices involving large tonnage and high-speed conveyors.

Through total customer focus, we provide intelligent solutions that deliver our customers a genuine quality product at internationally competitive prices.

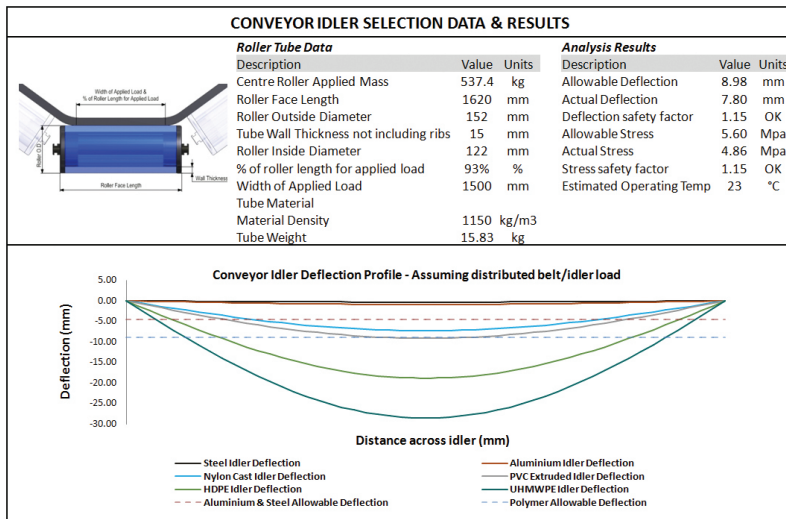

Engineering Solutions

We are focused

Manufacturing

Flexible Responsive Manufacturing

We are committed to using advanced manufacturing equipment and up to date manufacturing process to produce the highest quality products. Our automated production lines enable us to constantly and accurately produce to the required specification. Our approach to flexible manufacturing enables us to deliver the correct solution on time.



Product Development & Continuous Product Improvement

We have developed a world class-testing laboratory where our research and development team is focused on designing new and cost-effective roller solutions that meet the specification and application needs of our customers. Using advanced testing equipment we can quickly and accurately validate the roller performance.

The following tests are carried out to ensure the products meet our customer's requirements:

- Dimensional defects, shaft angle load tests, roller balance
- Visual defects, eccentricity & starting torque test
- Rim drag, dust penetration & water ingress



Research and Development

on your business

Quality

Quality Management Systems

Our commitment to producing and supplying the highest quality products are guaranteed through our Quality System Certification ISO 9001:2008, SIRM QAS International, and our product solution R and D. Product and service quality are given the highest priority. From the design stage, all the way to delivery, our people are trained in quality methods and principles. At every level within the organization, we are engaged in improving product quality and processes. To maintain a high level of quality, we have a comprehensive Inspection and Test Plan, along with a detailed MDR process that is strictly adhered to.



Critical Roller Features

Hi-Quality Balanced Tube

STEEL: HD NYLON: ALUMINIUM

It is critical that the Total Indicator Run Out (TIR) is kept to a minimum. Excessive TIR and MIS (Mean Indicator Slope) causes belt flap, vibrations and reduces bearing life. It is even more critical when producing low noise rollers, which are becoming increasingly important in today's environment.

Greater Bearing Life

There are a number of principles that need to be followed to achieve increased bearing life. To achieve the best possible service life, shaft selection is critical and must be designed to reflect the correct running capability of the conveyor and incorporate the below:

- Carried material
- Flooded belt loading
- Belt mass

This helps minimize angular misalignment in the bearing caused by shaft deflection.

As the shaft is only supported at each end, it must also accept the load from the shell to the bearings at each end. It is critical to minimize the angular deflection at the bearings. Bearings must have a L10 basic rating life of 65,000 hours (or as specified by the client) for bearing loads encountered at the operating design duty, calculated in accordance with AS2729.

Shaft Detail

The shafts consist of cold drawn mild steel-polished round bars in accordance with JIS-G3123 SGD 3 and other equivalent standards. Black shafts -JIS-G 3101-SS400 equivalent to ASNZS3679 are machined for "step-down" for respective bearing fitting. Particular attention is given to the bearing seat machining and seal location.

End Housings

The end discs are fabricated from ASNZS1594, JIS-G-3131 -pickled and oiled-coils. The fabrication of the end housing consists of a multi-stage precision automatic pressing operation, which provides such a high degree of accuracy for bearing and seal location, that no further machining is necessary. The end housings are chemically degreased after manufacture.

Roller Seal Packages

One of the most important aspects to the service life of a roller, is the sealing arrangement. **There are** 3 sealing arrangements available, depending on the duty requirements.

RS Premium Seal Package, TK2 Seal Package, Low Roll Resistant Seal Package

Starting from the external side, the various protective elements are:

- Protective anti-corrosive shield located firmly on the shaft, which acts as a barrier against the entry of foreign particles
- Low friction rubber lip seal to prevent the entry of liquid
- Steel cover cap with a large chamber where any dust particle that might enter is trapped
- Triple labyrinth male preloaded with grease seal is installed
- Triple labyrinth female preloaded with grease seal covers the male labyrinth to form the last barrier of defence before the bearing
- Rear seal is fitted to protect the bearing from mill scaling and any inherent contaminant.

Idler Roller Bearings

High quality bearings are essential to the life of a roller. **Our** range of quality bearings **are**, SKF, NTN, NSK and **our in-house** bearings. Rollers are fitted with single row deep groove ZZ type ball bearings with a C3 internal clearance unless otherwise specified. The bearings are factory greased for life with a suitable Lithium based grease with a NLGI consistency of 2 for bearings ≤ 6206 and consistency of 3 for bearings ≥ 6306 , this offers minimum roller drag and gives maximum resistance to water wash out.

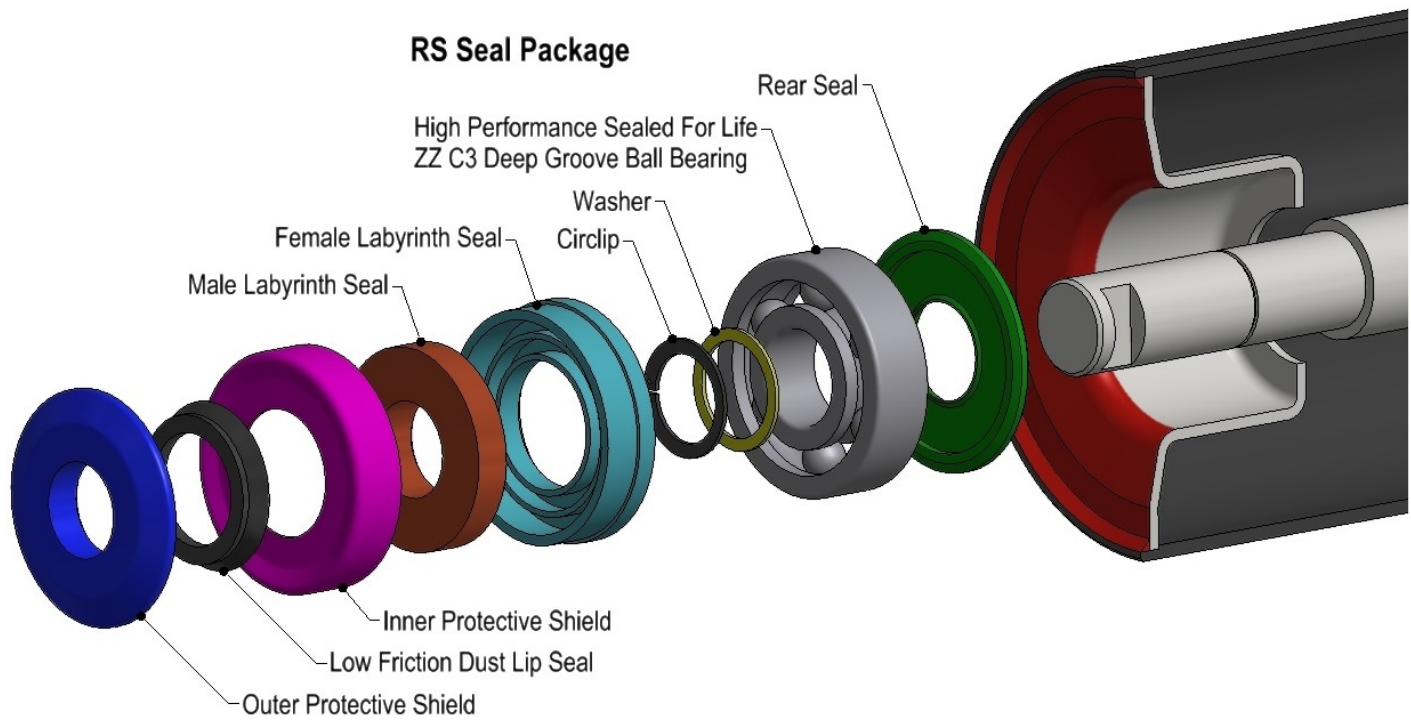

Housing Tube Weld Detail

The idler shells and end housings are 3mm CF fully fillet welded in a special double-ended automatic circumferential welding machine, which gives a minimum of 70% weld penetration and ensures that the shell tubing is concentric at the ends during the welding process, thereby ensuring minimum run-out for the roller as per the BS EN 288 Part 3 ~Acceptance Criteria: ISO 5817:1992 Quality Level or AS/NZS 1554 Part 1-Category-GPand SP.

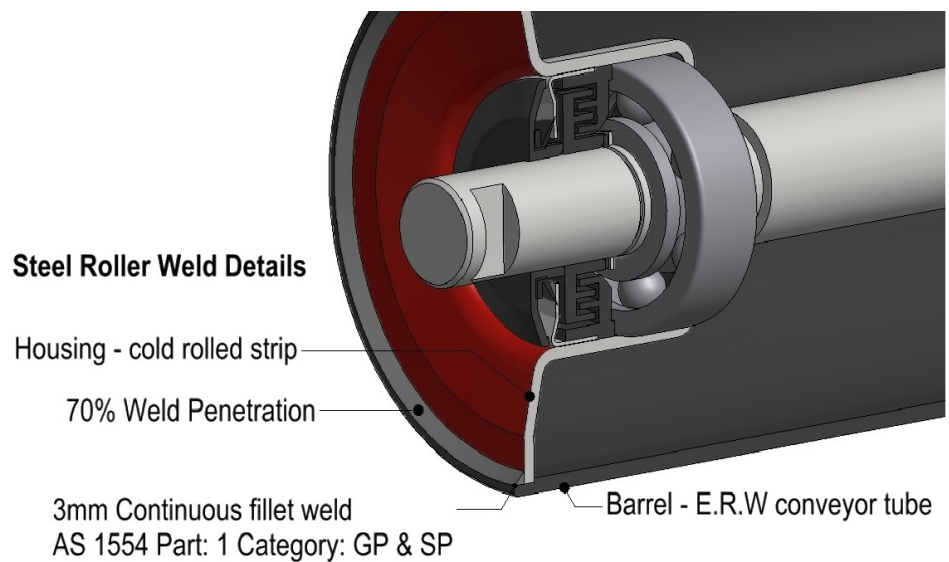

PRODUCT RANGE

We developed a comprehensive product range that provides our clients with suitable rollers for any application. We use our computerised idler design program, to help select the best possible roller to suit the client's budget and service life expectancy.

The following products, are available in both our premium RS model, or our economical TK2 model.

Plain Steel Rollers

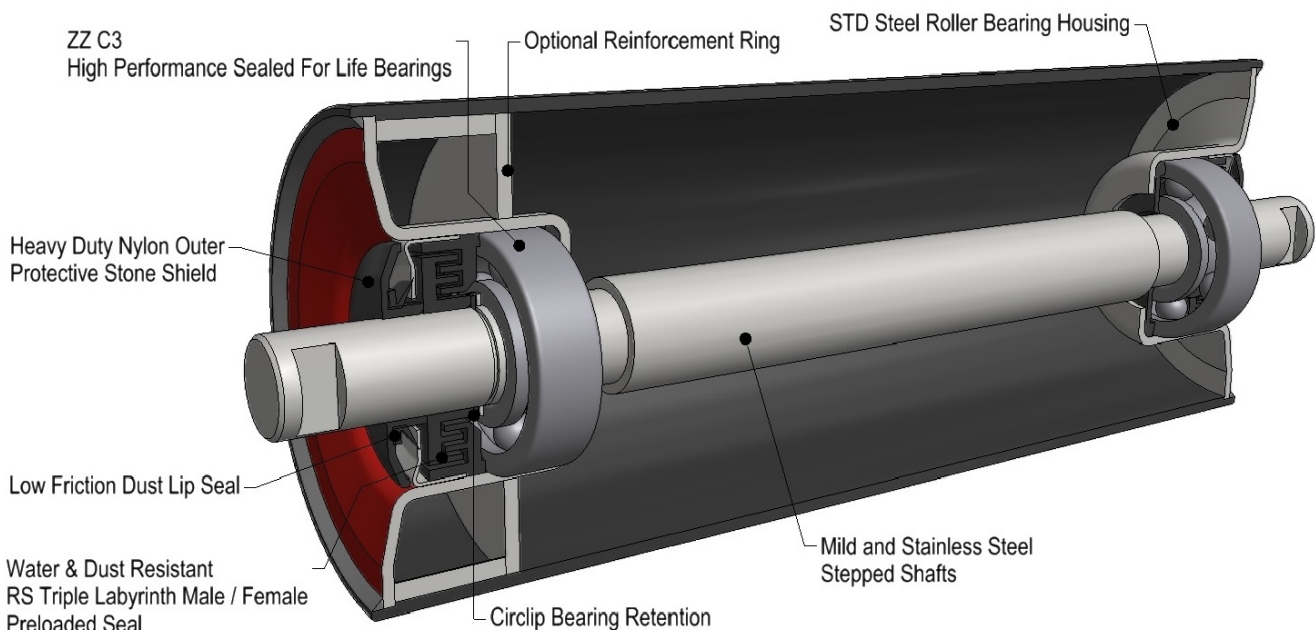

Steel Roller Tube

The tube is rolled from electric-resistance-weld ERW 200 -350 range tube, using prime quality steel as per AS1450, BS 1387:1985; GB/T 13792-92 and other equivalent standards for conveyor tubing. Each shell end is precision machined to fit the end housing to ensure concentricity.

Steel Roller Surface Treatment

Rollers are firstly put through a de-scaling machine that removes any rust or scale build up before they are solvent cleaned, prior to being coated in an anti-rust inhibitor. The roller ends are then sprayed in enamel paint with a specific colour code that identifies the type. Shells and ends can be hot dipped galvanized, or coated with corrosion protective painting systems on request.

Impact Rollers

We provides a variety of impact rollers including:

- High impact bull nose poly rollers
- Rubber disc impact rollers
- Mines Department approved FRAS rubber impact rollers

Rubber or poly impacts are a highly effective way to dampen the impact load and hence improve the life span of the rollers used in the impact zone. The rollers are fitted with single row deep groove ball bearings, but in extreme conditions spherical roller bearings are used, which have a greater tolerance to shaft deflection and a higher dynamic capacity. Our impact rollers also use a variety of reinforced bearing housings to adapt to the various drop heights and lump sizes seen in the impact zone.

Rubber disc impacts use press fitted rubber disc's and a welded retaining ring at each end of the roller is used to ensure the rubber disc's are firmly clamped and retained in position during operation.

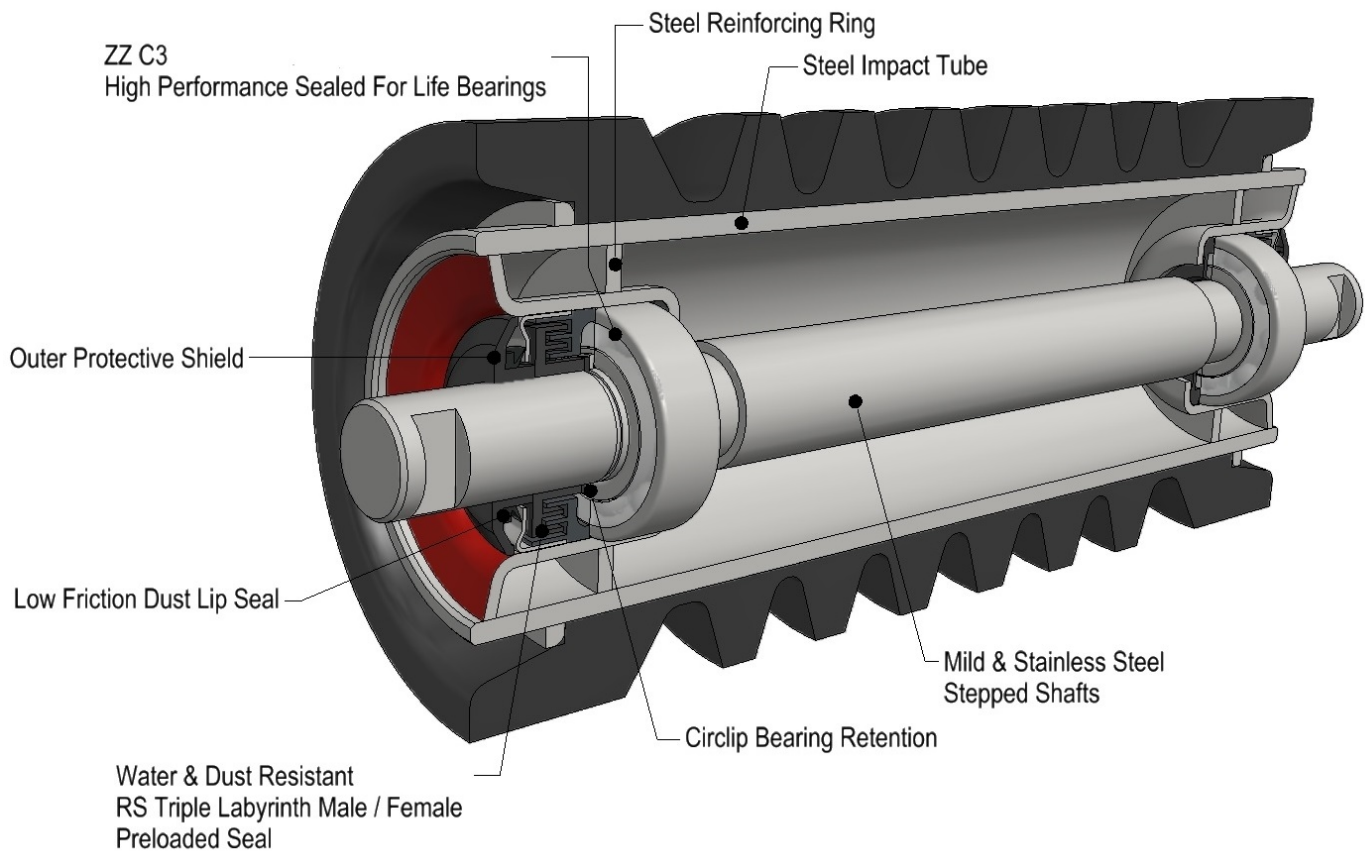

High Performance Heavy Duty Rollers

Dynamically Balanced Steel Low Noise and Weigh Quality Rollers

Steel rollers, using our heavy duty steel housings, welded into the tube like a conveyor pulley, provide ultimate strength and life of a roller, due to the weld not being exposed to the shell, there is minimal belt wear over time which increases the life of the roller. Typically used on large tonnage high-speed conveyors, often carrying iron ore, and ideal around port facilities, close to residential areas.

It is paramount to start with a good quality tube that has minimal TIR. This will ensure minimal machining of the shell, whilst maintaining an acceptable wall thickness after machining. It is also important that the machining process used, eliminates the chatter and resonating effect that leaves a rough surface and varying wall thickness along the tube surface, which reduces the ability to meet the required MIS specification. The heavy-duty housings are precision machined on the flange and bore to guarantee 100% concentricity.

The disc reinforcement on the inner end of the heavy-duty housing eliminates movement caused by heavy loads, thus preventing housing / weld failure due to stress reversals

To accurately balance low noise and weigh quality rollers to the specified G number in a minimum amount of time, a purpose-built Dynamic Balance Machine is paramount, The machine needs to have variable speed so that the belt speed / roller RPM for a particular project can be met, and be adjustable to take different length rollers.

Using our Dynamic Balance machines, together with our unique manufacturing process, we are able to accurately and quickly dynamic balance our low noise rollers to AS3709 grade G16 or 0.05Nm, and weigh rollers to AS3709 grade G16, or 0.014Nm.

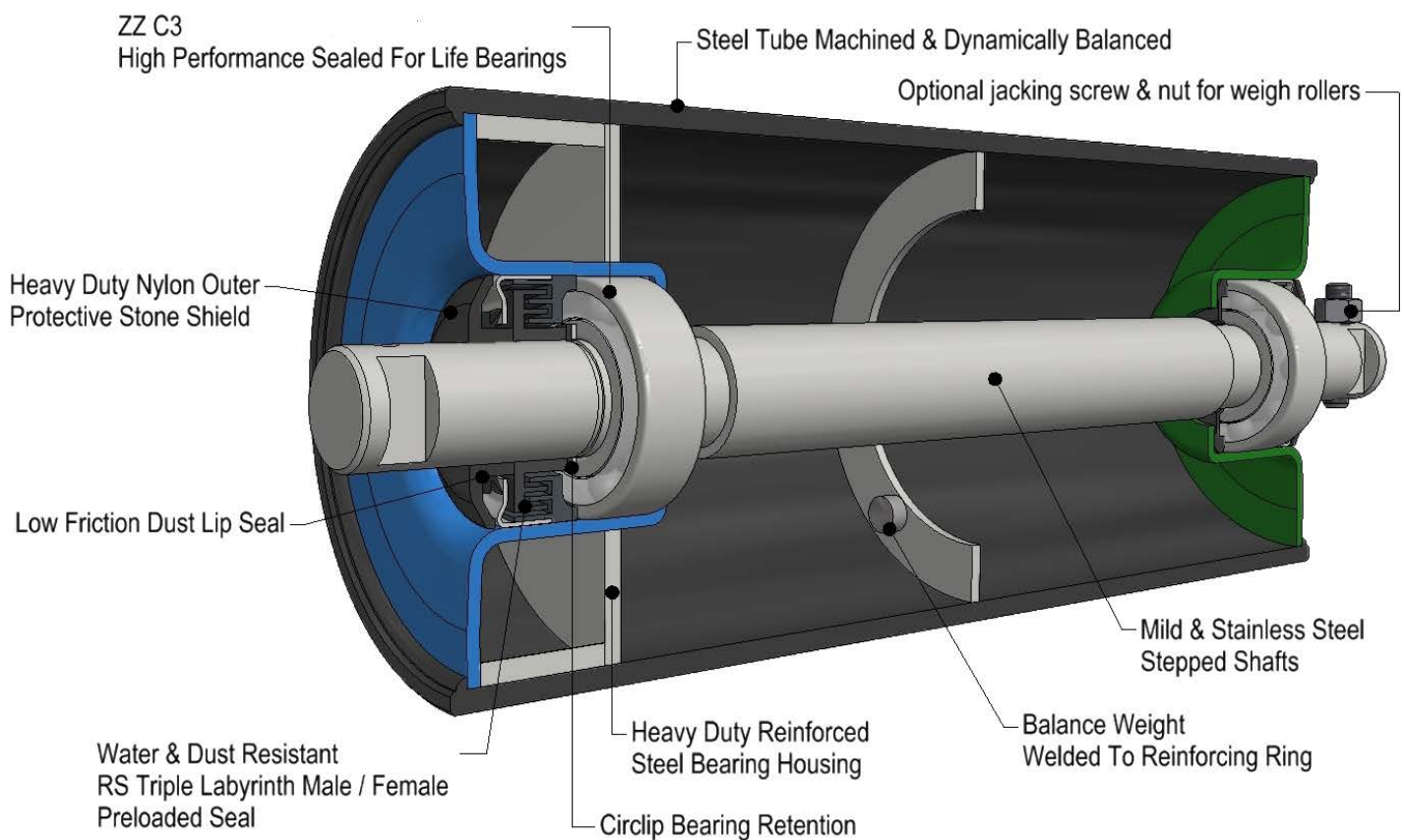

Heavy Duty Plain Steel Rollers

Suitable for large tonnage, high-speed conveyors.

Typical Heavy Duty Steel Roller

Heavy Duty Solid Steel Housings. These end housings are precision machined from a solid steel block and totally eliminate any chance of deflection.

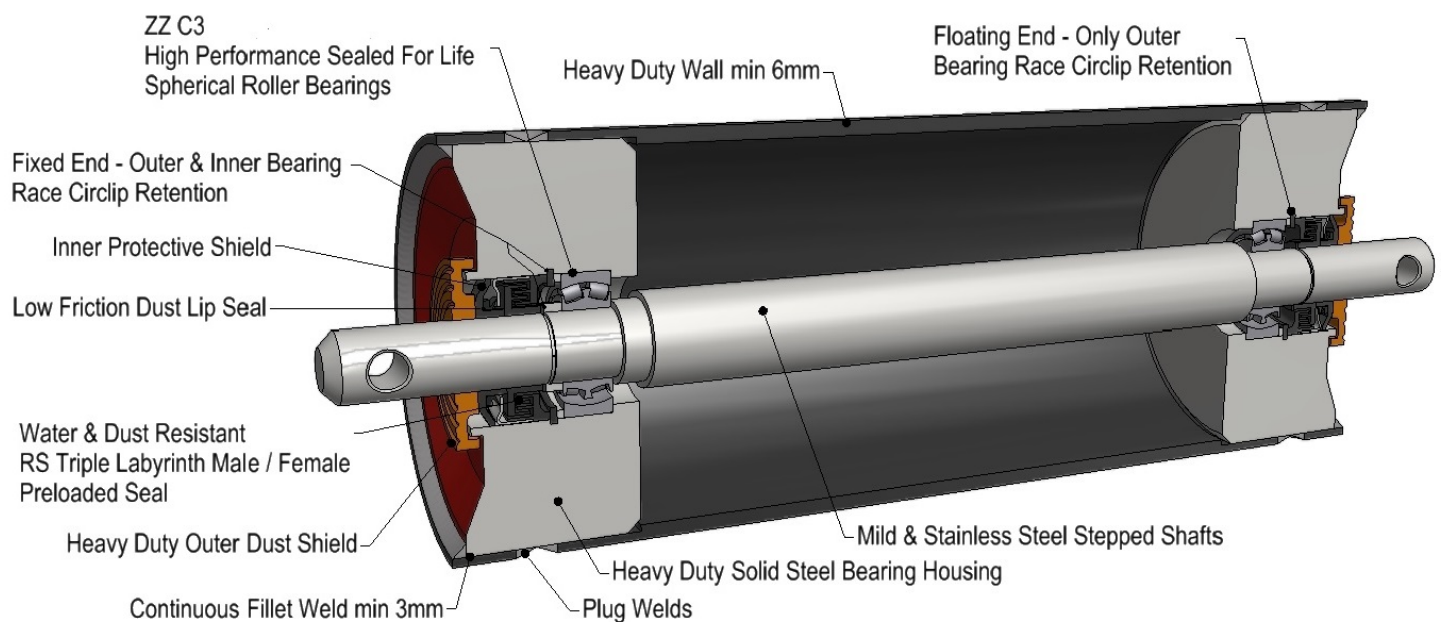

Heavy Duty Shaft & Bearing Retention

As shown in the illustrations, consistent with the bearing manufacturer's recommendations, **our design** have a "fixed" and "floating" end. This allows the shaft to slide in the bearing inner race on one end to prevent loading up the balls and or rollers on the outer race during any deflections, expansion or contractions. Both outer races are an interference fit in the housing and are located with circlips to prevent any axial movement. One end only on the inner race is located on the stepped -shaft shoulder with a spacer and circlip.

Heavy Duty Rubber and Poly Impact Rollers

Heavy Duty Impact Rollers are typically used in heavy-duty mining applications such as impact zones on over burden conveyors.

Typical Heavy Duty Impact Roller

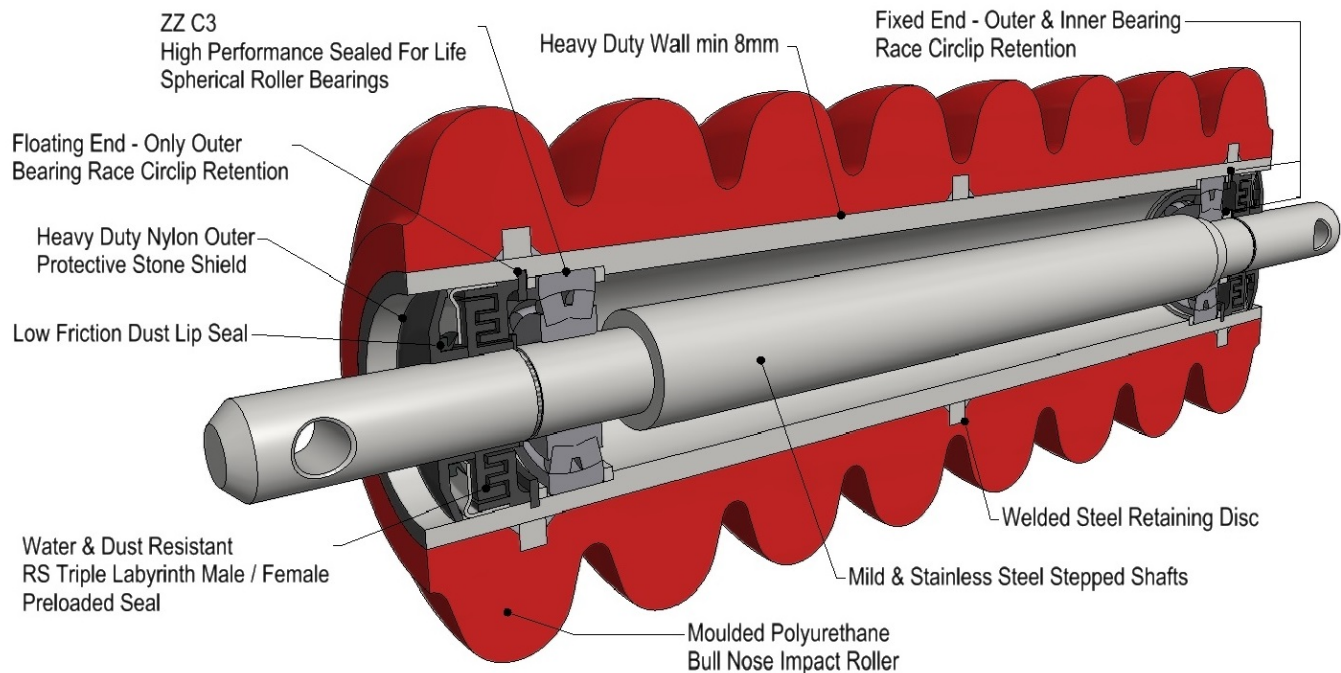

They can be used as a complete multiple roller Impact Idler Set, or commonly used in a 5 roll set in the centre locations to absorb high impact loads, with two steel rollers in the wing location under the skirting area.

The Impact Roller has as an added feature where the heavy-duty polyurethane "Bull Nose" discs are keyed to the shell tube to prevent "walking off".

Where extra high Dynamic Rating Bearings are needed, with a greater tolerance to shaft deflections, spherical roller bearings with common physical dimensions to the Single Row Deep Groove type, are used as shown in the illustrations. The bearings are factory greased for life with Shell Alvania HDX2 or approved equivalent by the bearing manufacturer. This offers maximum protection to impact forces and resistance to water wash out.

Steel Composite & Low Noise Steel Composite Rollers

(Steel shell with poly housings) more commonly used as a medium duty roller where the load is not sufficient enough to cause the resilience in the poly housing to prematurely wear the bearing fitment in the housing.

The added advantage of poly housings, is that they offer a slightly better noise reduction, due to its resilience and sound absorption. A good quality tube with minimal TIR is essential, along with precision injection moulded bearing housings.

Both rollers come in the RS model high performance water / dust resistance sealing, or the TK2 model sealing, which offers less drag, but has less resistance to water ingress.

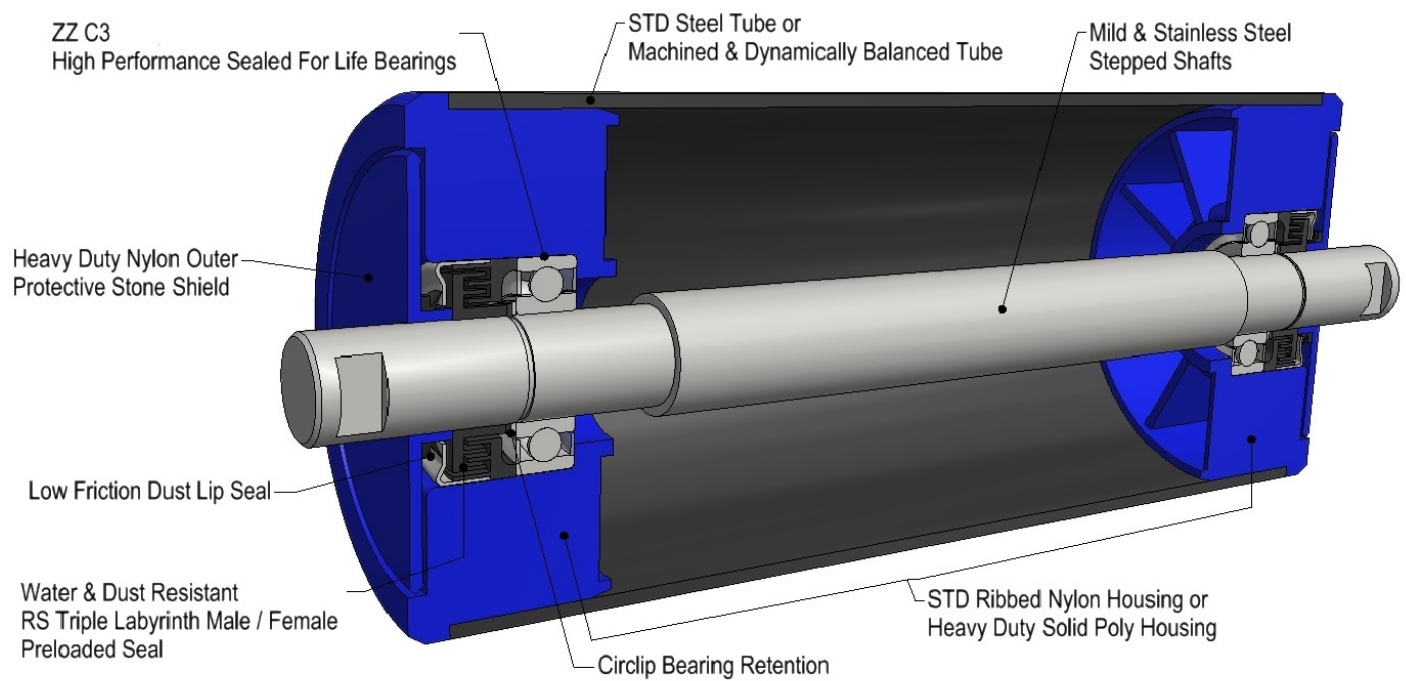

Aluminium Rollers

Aluminium rollers are commonly used in the coal industry, as they are light weight and low noise. They are available in the RS model, with either the heavy duty nylon composite housing, or the standard composite housing.

Alloy Shell – Poly Bearing Housings – Roller Features

- **Shells** are made from a high grade light weight, specially formulated Aluminium alloy
- **End Housings** are an interference fit into the tube ends and solid in construction.
Material: Specially formulated polyurethane.
- **Weight** of the RKM Aluminium roller is OH&S friendly, due to light mass. Hollow shafts are used where necessary, to keep the mass down to the client's specification.
- **TIR** (Total Indicator Run out) and **MIS** (Mean Indicator Slope) compliant.
- **Balance Quality** G16 or 0.05 Nm to ISO3709.
- **Roller Material Build Up** has good properties against build up.
- **Low Noise**, which meets customer's specifications

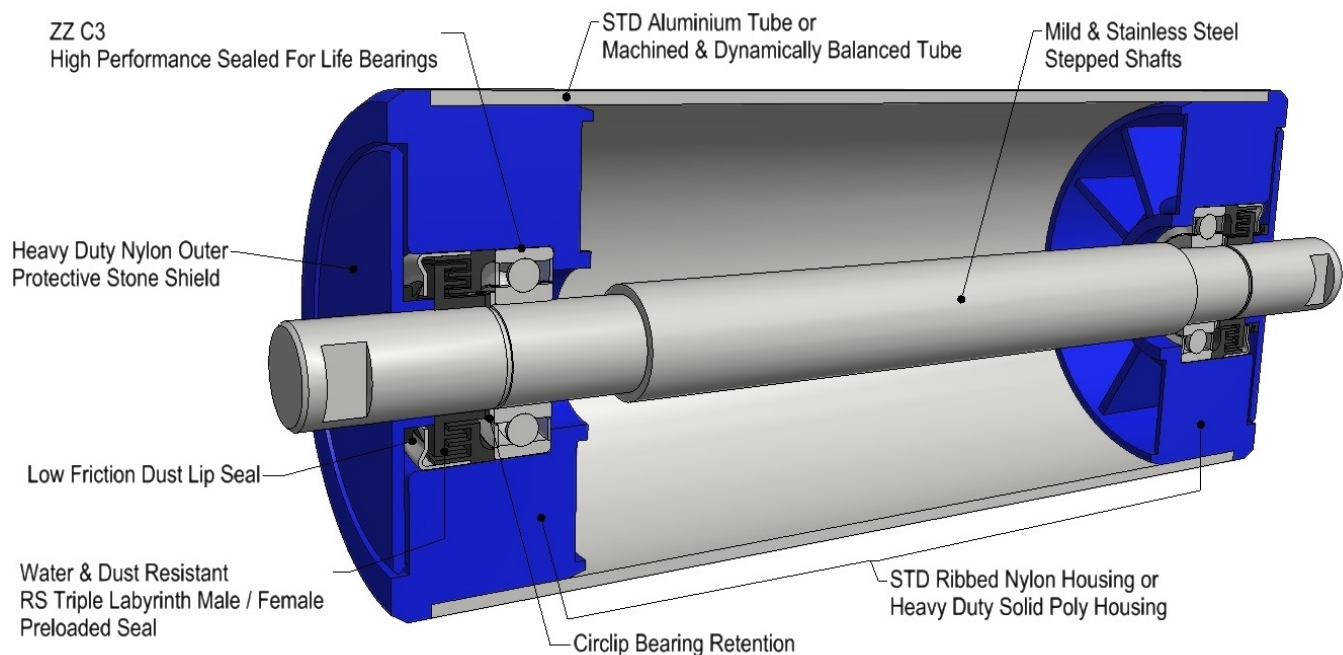

HD Nylon Plastic Rollers

Our range of plastic rollers are suitable for different applications, both in medium and heavy duty.

Our unique manufacturing process, also allows us to meet minimal TIR requirements and be able to dynamically balance the roller to the G number required.

Our purpose built design program, enables us to evaluate the stress and deflection of a plastic roller shell under specific loading conditions. Once the calculations are complete, we can then provide the customer with a detailed, one page print out, including graphs, showing the allowable and actual loads and stresses that are being applied to the roller. From there, we are able to offer the correct plastic roller suitable for the application, using the correct shell thickness along with the correct seal and housing package to suit the client's budget and service life expectancy.

Roller Features and Benefits

- **Roller Shells** – are made from a high grade Nylon. It is a thermoplastic with the highest Yield Strength and Flexural Elastic Modulus of 2800 MPa, compared with all other plastics. This gives it the unique properties of excellent impact strength, wear and abrasion resistance. The heavy-duty nylon housing, giving a larger surface bond between the shell and housing, eliminates any flexing within the housing where the bearings and seals are located. Together with a high resistance to chemical agents, this makes the roller suitable for a wide range of applications.
- High impact strength
- Excellent abrasion resistance, better than carbon steel for sliding abrasion
- Low coefficient of friction, making it less susceptible to material build up
- Belt friendly material. Even advance wear on the shell will not damage the belt
- Non magnetic, so can be used when separating ferrous materials
- Low Noise
- Up to 50% lighter than steel and reduces potential for injuries during installation and manual handling

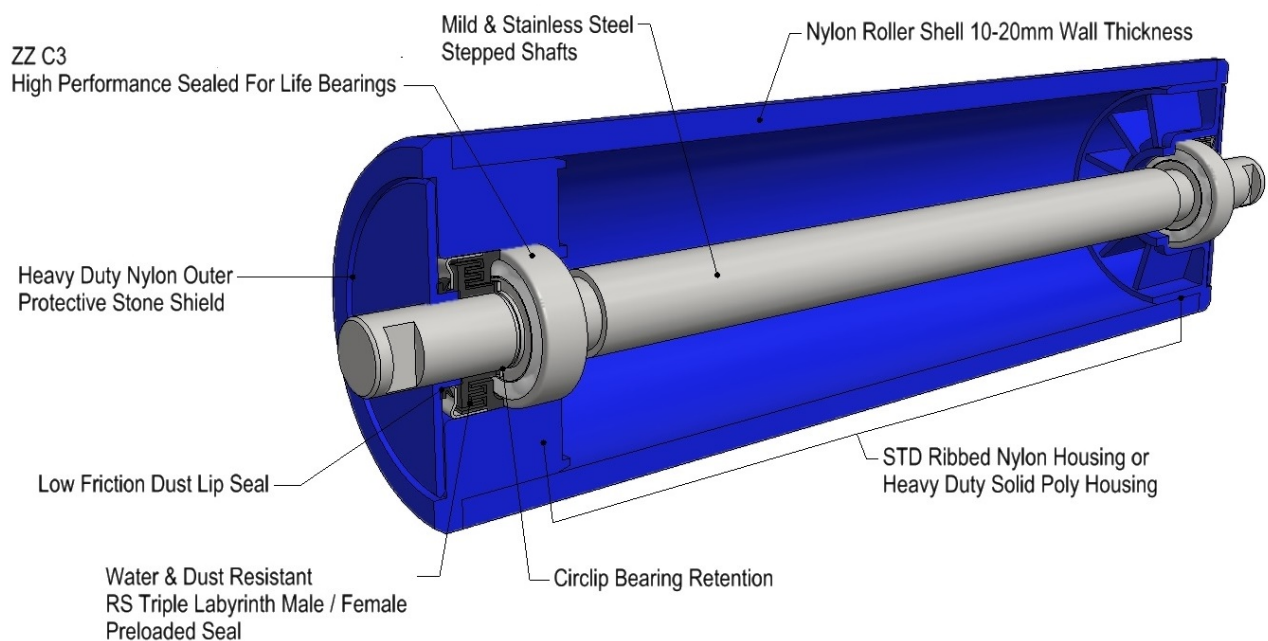

Tube Selection

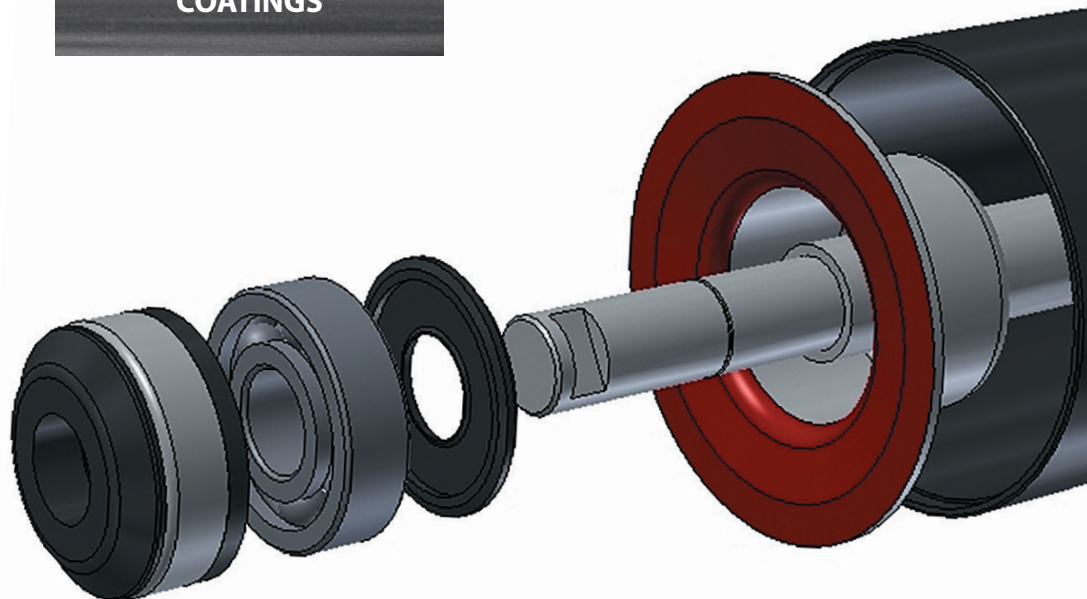

Shaft Selection

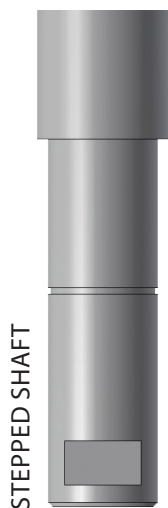
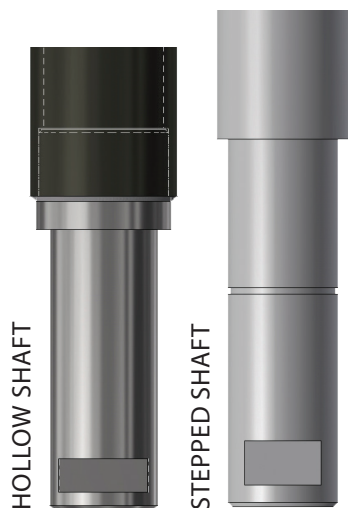

Bearing Selection

BALL BEARINGS

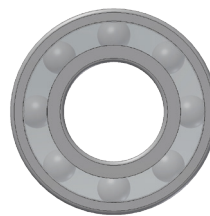

In-House

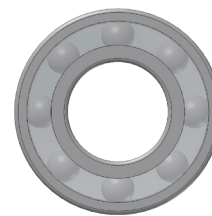

SKF, NSK, NTN

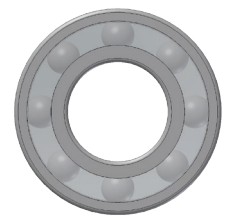

LOW RESISTANCE

Housing Selection



STD STEEL

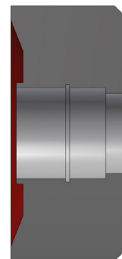

HD STEEL

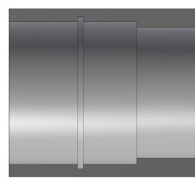

STEEL TUBE

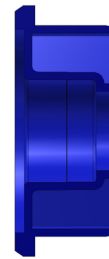

STD NYLON



HD NYLON

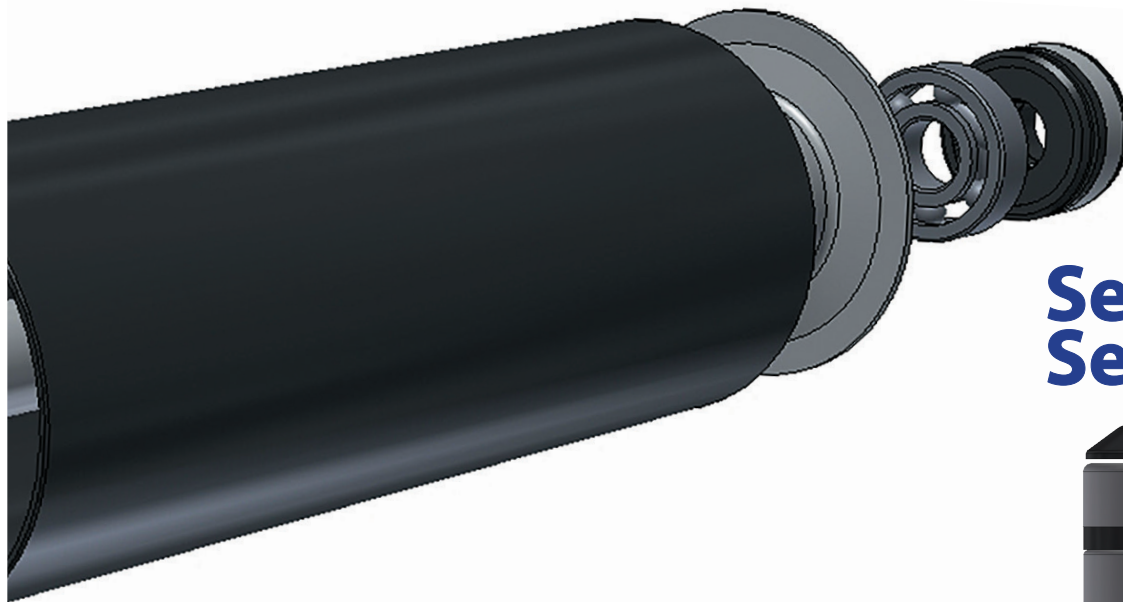

Seal Selection



RS SEAL



LRR SEAL



TK2 SEAL

Bearing Selection

SPHERICAL ROLLER BEARINGS



In-House



SKF, NSK, NTN

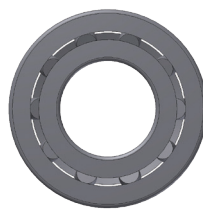

LOW RESISTANCE

FRAMES, BRACKETS & MINE STRUCTURE

We use the latest robotic welding technology as part of our commitment to ensuring a first-class weld is performed time after time. We conform to all international welding code specifications AS 1554 GP and AS 1554-SP.

We use Demmeler tables to assure our manufacturing tolerances are kept to the required standards, and that each jig is millimetre perfect. Our procedure also takes into account, the stress relieving process caused by the heat

generated through the welding process, along with the stress caused by the hot dip galvanizing.

Steel is made to ASNZS3679 or equivalent Asian standard. Jig welding of the base frames ensures slotted mounting brackets are accurately aligned. All frames and brackets are hot dip galvanised to AS NZS-4680, which gives affective resistance to a wide range of surface and underground environments.

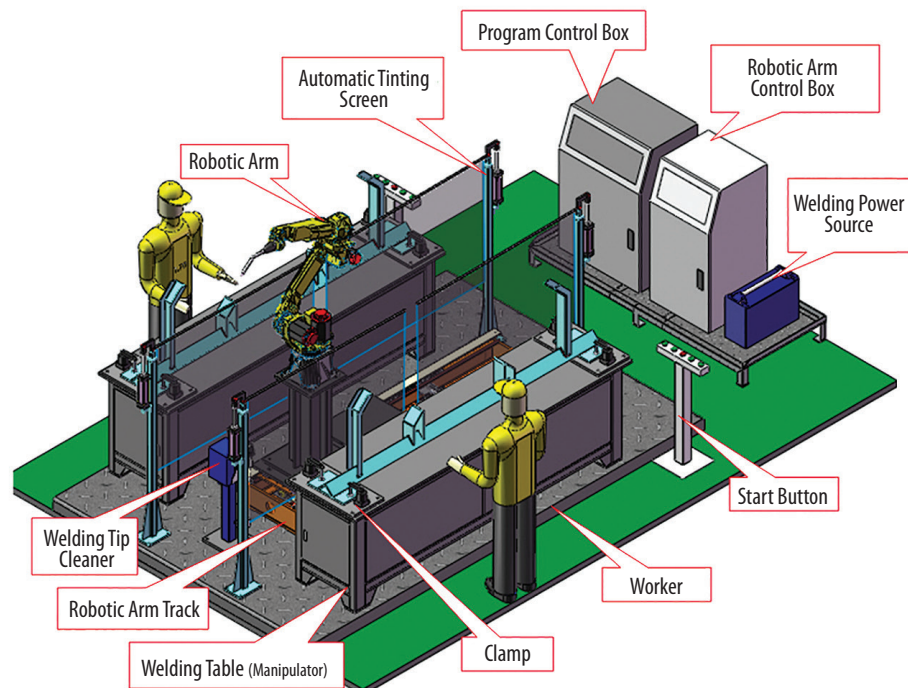

Frames & Brackets – General Specifications

- Frames and brackets are jig welded to idler bases to ensure the roller and troughing profile is maintained to within 2.0mm deviation.
- Frames and brackets are designed and manufactured to prevent distortion under torsional loads, resulting from both wing rollers being jammed.
- Impact idler bases of the heavy-duty retractable type, can be provided.
- Base frames are designed to self-shed material spilt from the belt.
- Wind guard mounting holes are provided in idler wing brackets.
- Trip wire pigtails share the wind guard holes.
- Idler brackets are designed to allow fitting of retaining

plates, clips and stone guards.

- Frames and brackets are provided with elongated fixing holes to suit minimum fixing bolt size M12.
- The clearance between idler rolls and frames are made sufficient to ensure that, should the rolling elements collapse within the roll bearings, a clearance is maintained between the idler rolls and frames.
- Brackets are slotted to accommodate drop-in dead shaft type rollers.
- Bracket slots are neat fitting to prevent rattling components during operation.
- In-line idlers have minimum end gaps between rollers to alleviate belt pinching.
- Trough idler frames for belts wider than 900mm are fitted with a diagonal brace between the outer support and the cross member.

Frames & Brackets – Surface Treatment

- Frames and brackets are grit blasted to class 2 ½ and hot dip galvanized, to AS NZS-4680 or equivalent Asian standard, for greater corrosion resistance and durability in a wide range of surface and underground environments. Thickness is 450-600g/m². Mechanical cleaning followed by enamel paint is available on request.
- Special epoxy painting to suit corrosive environments where galvanizing is not suitable, such as gold mines and salt water is also available.

IDLER CONFIGURATIONS

Below is a guide to various idler configurations and their uses.

Three Roll Trough 20 – 45 degrees range, most commonly used configuration for Carry Idler Sets, Three Roll Weigh Idlers 20 – 45 degrees range

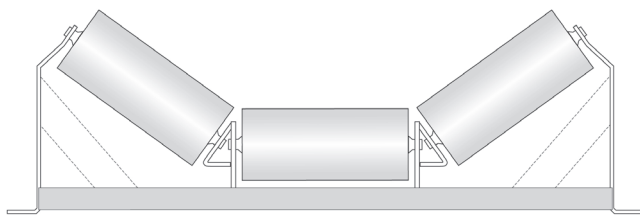

Offset used to assist belt tracking for mainly light and medium duty, up to 1200mm belt. Inline used mainly for medium to heavy duty and belt widths above 1200mm.

Used on weigh machines or load cells, lead in and lead out sets (which have machined and balanced rollers to ensure zero vibration) and jacking screws or cams to ensure consistent sectional profile and alignment so calibration is not affected.

Three Roll Trough Impact 20 – 45 degrees Range

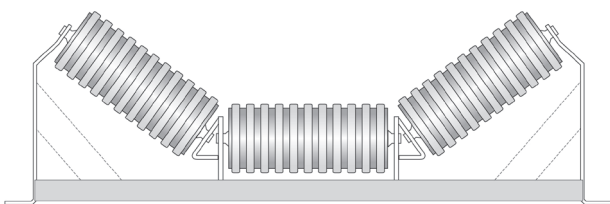

Installed at the loading point to absorb the shocks and to help protect against belt damage. Retractable sets are also used in the skirt area, allowing the rollers to be changed out without disturbing the skirting.

Three Roll Suspended (Catenary) Trough and Impact idlers – 20 – 45 degrees Range

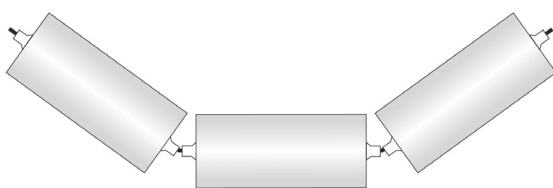

Due to the swing nature this absorbs high impact and less dynamic loads on the rollers. Used in demountable mine structures such as gate conveyors as it is easy to change out and re install.

Three Roll Adjustable transition idlers, usually in increments to a maximum range of 15 degrees

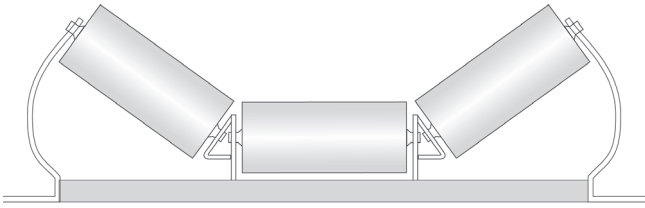

Used at head and tail position to support the belt as it goes from the trough to the flat position.

Three Roll Trough Picking idlers, usually 20 degrees

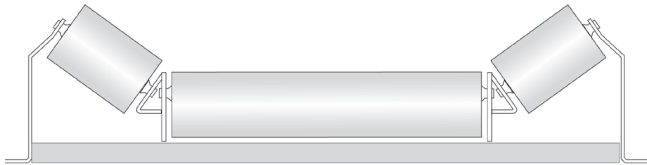

Has a long centre roller and short wing roller, used in waste recycling plants to manually separate materials and also belt feeder applications.

Single Roll Flat carrying plain idlers



Not used very much due to no protection against spillage that trough sets give. Also used in the skirt area outbye of bin and feeder loading area.

Single or Vee Roll Rubber disc return idlers, usually 10 – 20 degrees



Used in wet, sticky or abrasive conditions. Helps belt tracking due to less build up.

Trough Training Idlers, anti-friction or poly pad swivel top frame, activated by servo rollers

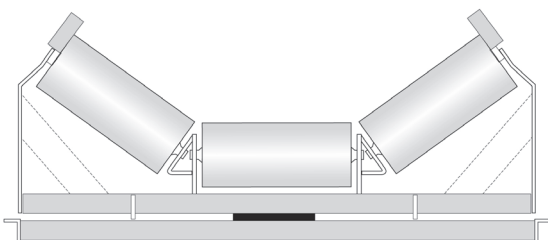

Used to train the belt approaching the head end of the conveyor.

Return Training idlers, anti-friction or poly pad swivel top frame, activated by servo rollers



Used to train the belt approaching the tail end of the conveyor.

Trough and return side guides

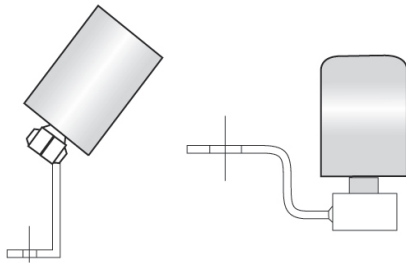

Prevents the belt hitting and wearing out the structure. Can be used for tracking but it is not advised due to belt damage.

Single Roll Flat Impact Carry idlers

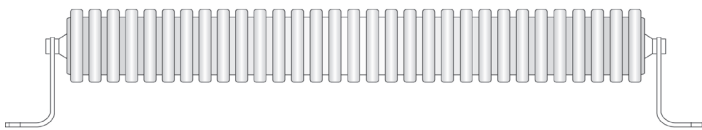

Used in the skirt area under bins and feeders loading area.

Inverted Vee Training idler

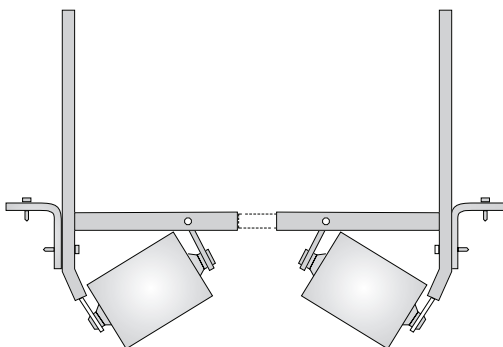

Used to train the belt, mainly approaching the tail end of the conveyor. Two trough rollers are usually used with keeper plates to stop the rollers falling out.

Special Trough and Return Side guide roller various belt widths

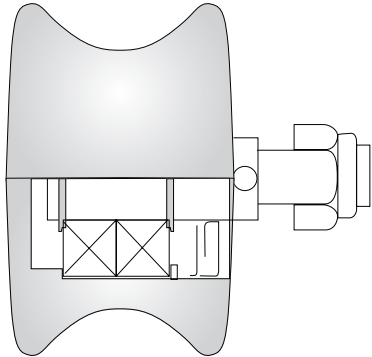

Used extensively on overland conveyors with horizontal curves, to prevent the belt transversely riding up over the trough and/ or return idler sets.

Drop Down Idler Sets

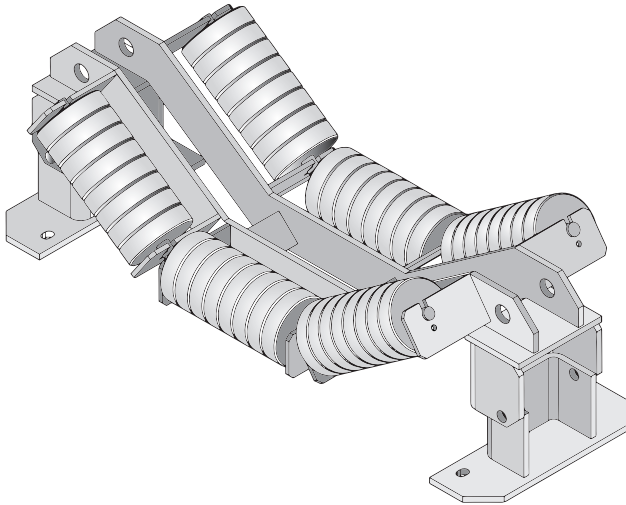

Extra Heavy Duty in skirted areas, with adjustable legs which allows the rollers to be lowered under the belt for easy removal and replacement..

Spiral Rollers

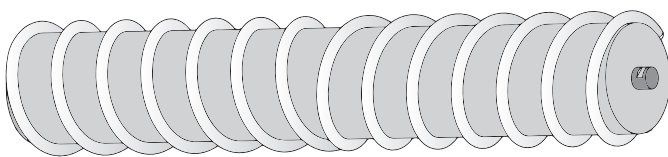

Very effective in the removal of material carry back on the return strand of the belt, particularly where belts have clipped joints where conventional scrapers are generally not used due to damage.

Three Roll Rigid Suspended Plain or Impact

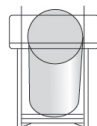
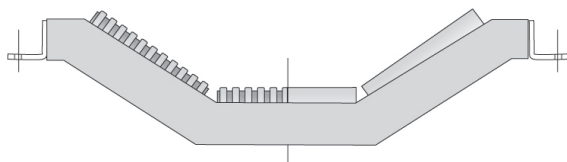

Four or Five Roll Inline Trough, Four or Five Roll Inline Trough Transition, Four or Five Roll Inline Trough Impact

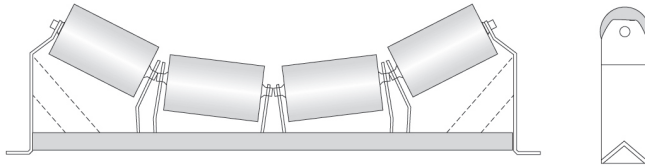

Four or Five Roll Trough Suspended

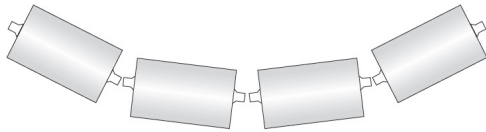

Three Roll Trough Suspended (various mounting types)

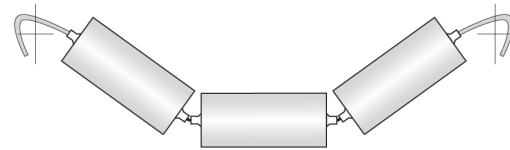

Retractable Idler Sets

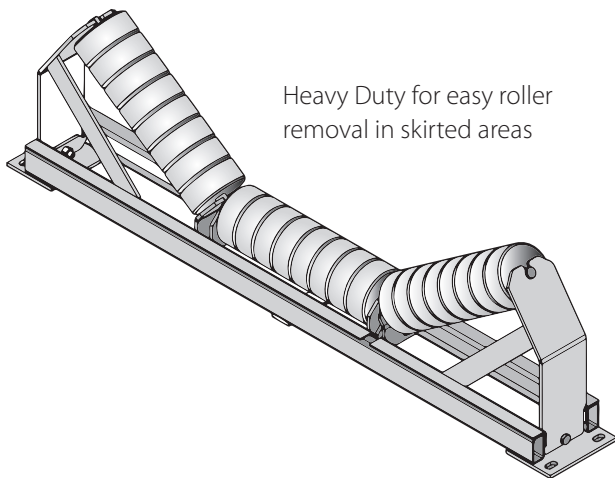

Heavy Duty for easy roller removal in skirted areas

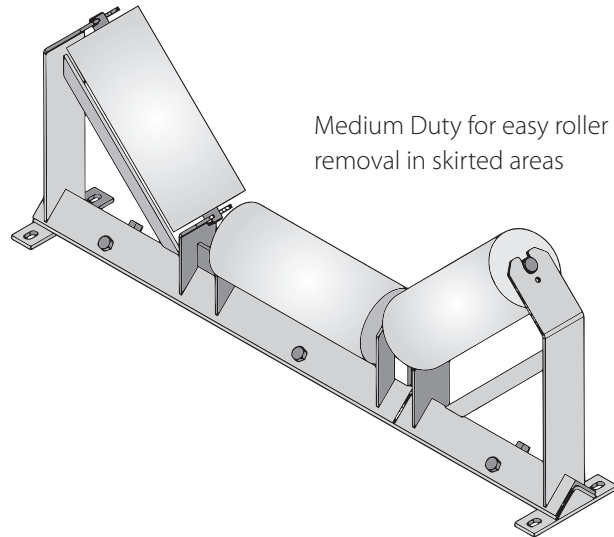

Medium Duty for easy roller removal in skirted areas

Mine Structure

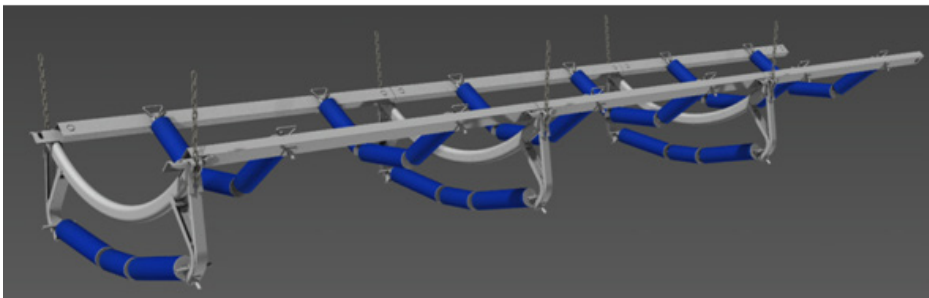

Through our in house design program, we can assist our customers in selecting and tailoring their own rollers to suit their specific site requirements, taking into account the duty requirements and conditions for each site along with any budgetary requirements.

Conveyor Idler Selection Data & Results

Roller Tube Data

Description	Value	Units
Centre Roller Applied Mass	537.4	kg
Roller Face Length	1620	mm
Roller Outside Diameter	152	mm
Tube Wall Thickness without ribs	15	mm
Roller Inside Diameter	122	mm
% of roller length for applied load	93%	%
Width of Applied Load	1500	mm
Tube Material		
Material Density	1150	kg/m ³
Tube Weight	15.83	kg

Analysis Results

Description	Value	Units
Allowable Deflection	8.98	mm
Actual Deflection	7.80	mm
Deflection safety factor	1.15	OK
Allowable Stress	5.60	Mpa
Actual Stress	4.86	Mpa
Stress safety factor	1.15	OK
Estimated Operating Temp	23	°C

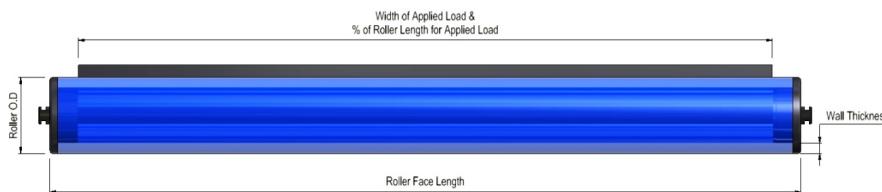
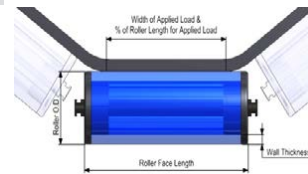

Conveyor Idler Load Profile - Aluminium & Steel

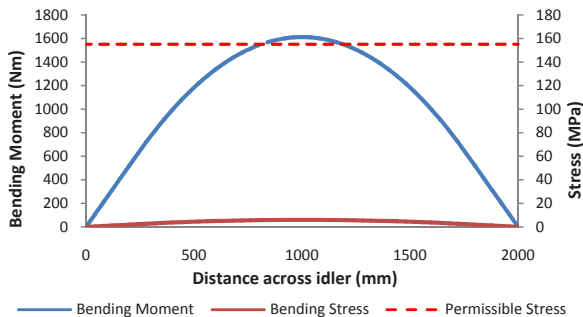

Conveyor Idler Load Profile - Polymers

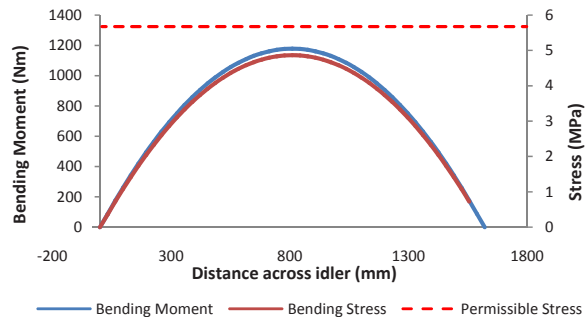

Conveyor Idler Deflection Profile - Assuming distributed belt/idler load

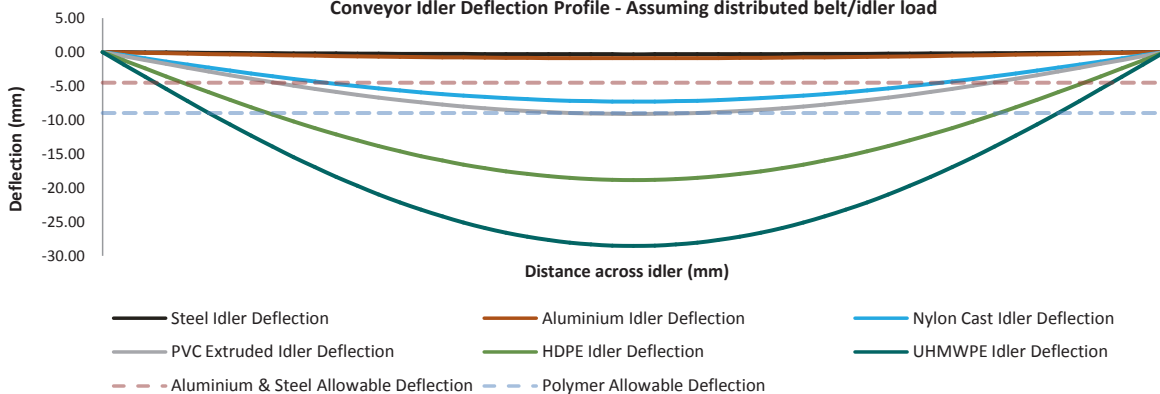

kingland



ENQUIRIES

Singapore

Phone +65 6369 3385
E-mail sales@kingland.asia
Address 205 Henderson Road
Unit 02-01,
Singapore 159549

Vietnam - HCMC

Phone +84 8 3512 3600
E-mail sales@kingland.asia
Address 28E, Nguyen Huu Canh,
Ward 22,
Binh Thanh District,
HCMC, Vietnam

China Manufacturing Facility

Phone +84 8 3512 3600
E-mail sales@kingland.asia
Address 广东省东莞市企石莫屋村远鑫工
业园区五街1号
No 1, Fifth Street, Yuanxin
Industrial Park, Mowu Village
Qishi Town, Dongguan City
Guangdong China